

SECTION 11110

LAUNDRY WASHER-EXTRACTOR, 60 LB. (27.2 KG) CAPACITY

PART 1 GENERAL

1.01 SECTION INCLUDES:

- A. Automatic laundry washer-extractor for processing water-washed linen items

1.02 SYSTEM DESCRIPTION

A. DESIGN REQUIREMENTS:

- 1. Construction: 304 or equal stainless steel cylinder, tub & cover panels
- 2. Input voltage: 208-240/60/3, 3 wire plus ground
- 3. Dry weight capacity: 60 lb. (27.3 kg)
- 4. Wash cylinder volume: 9.31 cu ft (264 L) minimum
- 5. Overall width: 36-5/8 inches (930 mm) nominal
- 6. Overall height: 64-1/2 inches (1638 mm) nominal
- 7. Overall depth: 45 inches (1143 mm) nominal
- 8. Number / size of water supply valves: [2] with 3/4 inch (19 mm) NH male connections
- 9. Number & size of drain outlets: 1 at 3 inch (76 mm)
- 10. Overflow: Internally plumbed
- 11. Control system: Programmable microprocessor
- 12. Cylinder drive: Single motor, 5 hp, capable of 469 RPM

B. PERFORMANCE REQUIREMENTS:

- 1. G-force at highest extract speed: 100
- 2. Chemical supply system
 - a. manually filled 5 compartment dry chemical dispensing system
 - b. automatic flushing & connections 4 external supply lines & control signals for 4 external supplies
- 3. Control system
 - a. Programmable microprocessor; (manual, PDA or laptop PC)
 - b. 30 programmable cycles
 - c. 31 programmable water levels
 - d. Real time clock to record events by date and time
 - e. Cycle counter
 - f. Temperature controlled fill and thermal cool-down
 - g. Water monitoring: slow drain and auto leak detection system
 - h. Diagnostic capabilities
- 4. Drain valve automatically opens in event of power failure

1.03 DELIVERY, STORAGE & HANDLING

A. ACCEPTANCE AT SITE:

1. Inspect machine for damage prior to acceptance. If damage is found, follow freight handler's procedure for claims.

B. STORAGE & PROTECTION

1. Machine should be stored in a site protected from weather, direct sunlight & temperature extremes. Do not remove packaging prior to storage.
2. If machine is to be stored for an extended period of time, consult manufacturer for special requirements.

1.04 SYSTEM STARTUP & COMMISSIONING

- A. Machine installation should be inspected by local manufacturer's representative prior to startup & operation. The party installing the machine is responsible for setting the schedule for this inspection.

PART 2 PRODUCTS

- A. Source quality
- B. Alliance Laundry Systems LLC - UniMac, obtain commercial laundry equipment from a single manufacturer

1.02 QUALIFIED MODELS

- A. UniMac model **UWN060K1L** (no substitutions)

PART 3 EXECUTION

1.01 INSTALLATION

- A. Refer to & comply with manufacturer's installation instructions. Do not deviate without permission from site owner, architect, general contractor & manufacturer's local representative.

Machine Dimensions and Specifications

Models UWN060K1LX and UWN060K1LR



Dimensions and Foundation Requirements

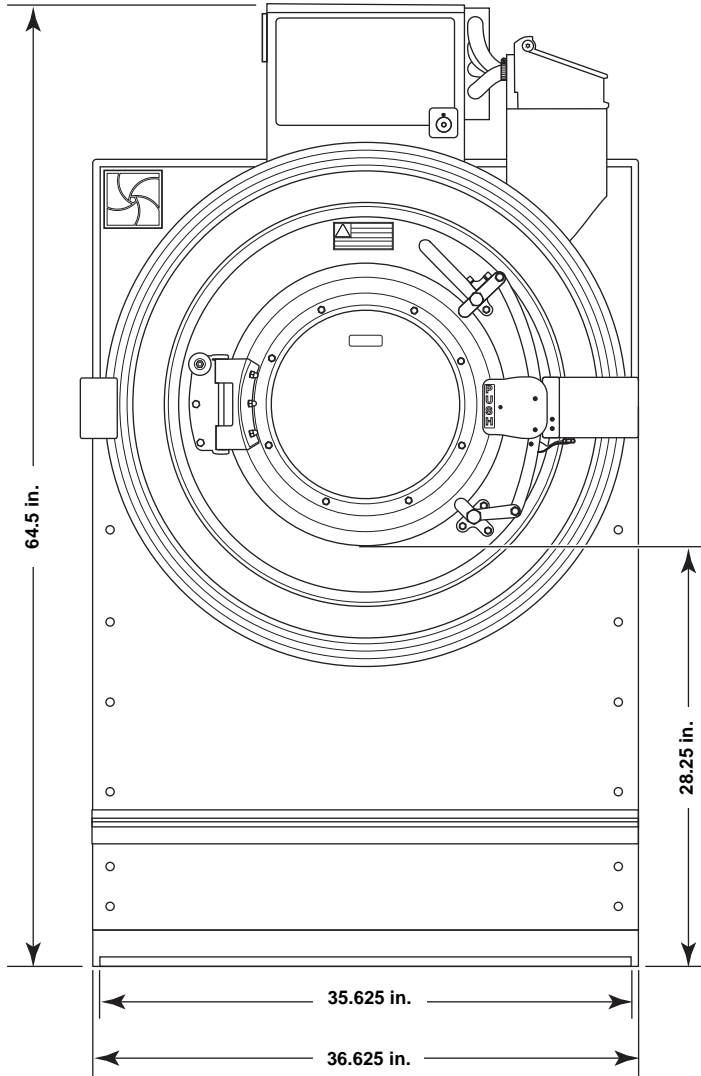

Front

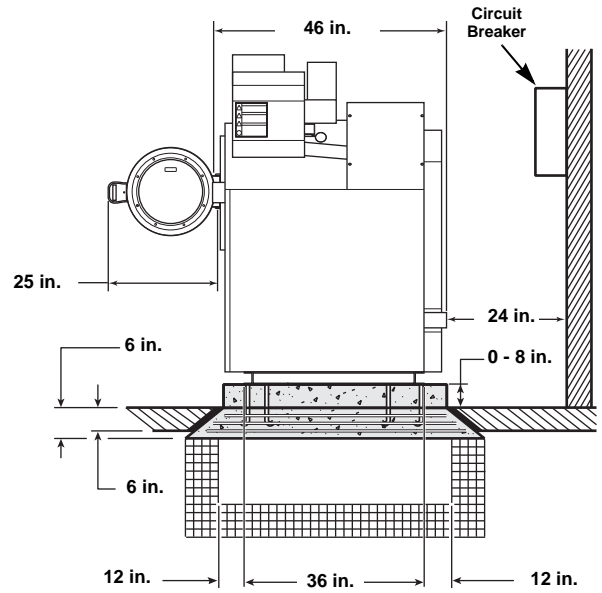

Right

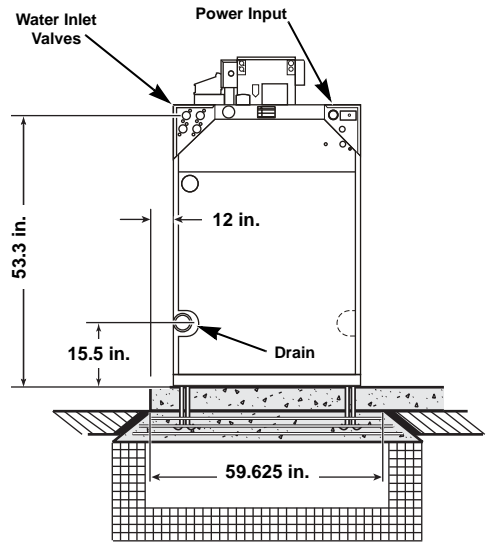

Back

PHM782N

Electrical Specifications

Voltage Designation					Non-Electric Heat Machines (Standard)			
Code	Voltage	Cycle	Phase	Wire	Full Load Amps	Breaker (Non Fused)	AWG	mm ²
X	200-240	50/60	1/3	2/3	15/9	20/15	12/14	4/2.5
R	308-480	50/60	3	3	7	15	14	2.5

Water, Drain and Weight Specifications

Drain: Number (Size)	1 (3 in.)
Fill Water Inlets: Number (Size)	2 (0.75 in.)
Weight: Machine (With Shipping Packaging)	1300 lbs. (1340 lbs.)
Side Clearance:	6 in. (minimum) 18 in. (recommended)