

SECTION 11110**LAUNDRY WASHER-EXTRACTOR, 80 LB CAPACITY****PART 1 GENERAL**

1.01 SECTION INCLUDES:

- A. Automatic laundry washer-extractor for processing water-washed linen items

1.02 SYSTEM DESCRIPTION

A. DESIGN REQUIREMENTS:

1. Construction: Stainless steel cylinder, tub and cover panels
2. Input voltage: X: 220-240/60/1 or 3; 2-3 wire plus ground
Q: 220-240/60/3; 3 wire plus ground
P: 380-415/50/3; 3 wire plus ground
N: 440-480/60/3; 3 wire plus ground
3. Dry weight capacity: 80 lb.
4. Wash cylinder volume: 12.4 cu ft. minimum
5. Overall width: 41.5 inches nominal
6. Overall height: 57.7 nches nominal
7. Overall depth: 48.6 inches nominal
8. Number and size of water connections: 2 with 3/4 NH male connections;
2 auxiliary with 3/4 NH male connections (hoses with y-connection installed)
9. Number and size of drain outlets: 1 at 3 inch
10. Overflow: Internally plumbed
11. Control system: Programmable microprocessor
12. Cylinder drive: Inverter drive, poly V belt system
13. Drive motor: 5 hp-inverter driven

B. PERFORMANCE REQUIREMENTS:

1. Number of selectable wash speeds: 2
2. Number of selectable extract speeds: 2
3. G-force at highest extract speed: 100
4. Chemical supply system
 - a. manually filled 4 compartment dry chemical dispensing system
 - b. automatic flushing and connections for 5 external supply lines and control signals for 4 external supplies

5. Control system
 - a. Programmable microprocessor; (manual, PDA or laptop PC)
 - b. 9 programmable cycles
 - c. 3 programmable water levels
 - d. Cycle counter
 - e. Thermal cool down
 - f. Water monitoring: fill value, slow drain and automatic leak detection system
 - g. Diagnostic capabilities
6. Drain valve automatically opens in event of power failure

1.03 DELIVERY, STORAGE AND HANDLING

A. ACCEPTANCE AT SITE:

1. Inspect machine for damage prior to acceptance. If damage is found, follow freight handler's procedure for claims.

B. STORAGE AND PROTECTION

1. Machine should be stored in a site protected from weather, direct sunlight and temperature extremes. Do not remove packaging prior to storage.
2. If machine is to be stored for an extended period of time, consult manufacturer for special requirements.

1.04 SYSTEM STARTUP AND COMMISSIONING

- A. Machine installation should be inspected by local manufacturer's representative prior to startup and operation. The party installing the machine is responsible for setting the schedule for this inspection.

PART 2 PRODUCTS

2.01 MANUFACTURERS

- A. Alliance Laundry Systems LLC - UniMac, obtain commercial laundry equipment from a single manufacturer

2.02 QUALIFIED MODELS

- A. UniMac model **UCN080HNF** (no substitutions permitted)

PART 3 EXECUTION

3.01 INSTALLATION

- A. Refer to and comply with manufacturer's installation instructions. Do not deviate without permission from site owner, architect, general contractor and manufacturer's local representative.

Machine Dimensions and Specifications

Model UCN080HNF



Design 2

Dimensions and Foundation Requirements

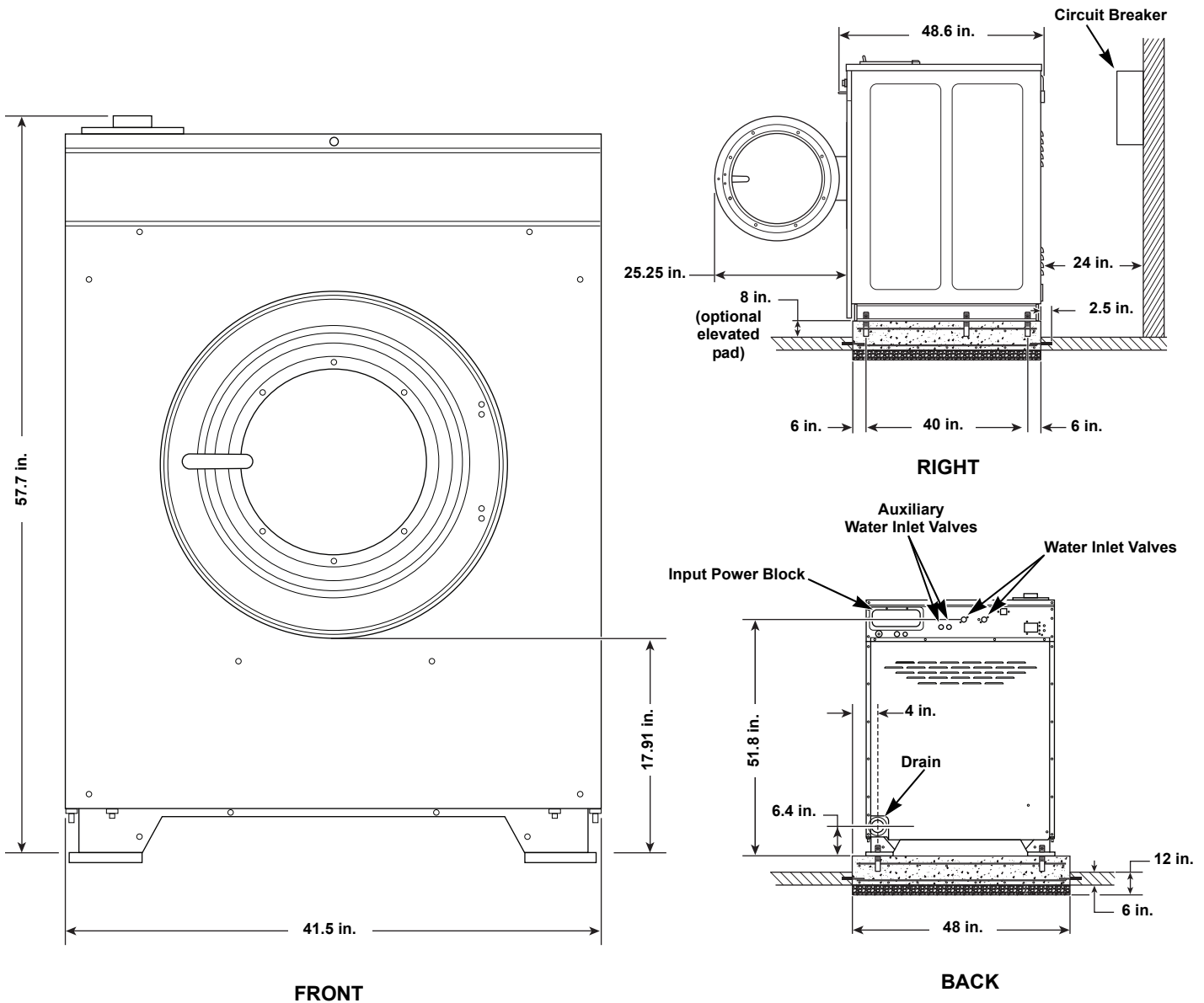

CHM2L

Electrical Specifications

Voltage Designation					Non-Electric Heat Machines (Standard)			
Code	Voltage	Cycle	Phase	Wire	Full Load Amps	Breaker (Non Fused)	AWG	mm ²
X	220-240	60	1/3	2/3	12	20/15	12/14	4/2.5
Q	220-240	60	3	3	8	15	14	2.5
P	380-415	50	3	3	5	15	14	2.5
N	440-480	60	3	3	5	15	14	2.5

Water, Drain and Weight Specifications

Drain: Number (Size)	1 (3 in.)
Water Connections: Number (Size)	2 (0.75 in.)
Weight: Machine (With Shipping Packaging)	1210 lbs. (1260 lbs.)
Side Clearance:	6 in. (from wall) 0.5 in. (between machines)